

OXV Technical Data

Vertical Order Picker

OXV 07/Li-Ion

OXV 08/Li-Ion

OXV 10/Li-Ion



OXV Vertical Order Picker Next Level Order Picking

This specification sheet, which conforms to VDI guideline 2198, provides the technical values for the standard equipment only. Different tyres, other masts, additional equipment, etc. may produce different values.



				STILL	STILL	STILL		
Features	1.1	Manufacturer						
	1.2	Manufacturer's type designation		OXV 07/Li-Ion	OXV 08/Li-Ion	OXV 10/Li-Ion		
	1.3	Drive		Electric	Electric	Electric		
	1.4	Operation		Stand-on	Stand-on	Stand-on		
	1.5	Nominal load capacity	Q	kg	700	800	1000	
	1.6	Load centre	c	mm	500	500	600	
	1.8	Load distance	x	mm	97	121	309	
	1.9	Wheel base	y	mm	1152	1380	1554	
	Weights	2.1	Service weight (incl. battery)		kg	1264	1576	1266
2.2		Axle load, laden	drive end/load end	kg	390/1574	512/1864	694/1572	
2.3		Axle load, unladen	drive end/load end	kg	766/498	892/684	890/376	
Wheels/chassis	3.1	Tyres			Polyurethane	Polyurethane	Polyurethane	
	3.2	Tyre size	drive end	mm	230 x 90	230 x 90	230 x 90	
	3.3	Tyre size	load end	mm	120 x 50	120 x 50	85 x 90	
	3.4	Support roller size		mm	100 x 40	100 x 40	150 x 50	
	3.5	Number of wheels (x = driven)	drive end/load end		1x - 2 / 4	1x - 2 / 4	1x - 1 / 2	
	3.6	Track width	drive end/load end	b ₁₀ /b ₁₁	mm	552/534	552/534	478/378
Basic dimensions	4.2	Height of mast when lowered		h ₁	mm	1373	1373	1373
	4.4	Lift		h ₃	mm	1050	1050	1050
	4.5	Height of mast when raised		h ₄	mm	2423	2423	2423
	4.8	Platform height		h ₇	mm	145	145	145
	4.9	Drawbar height in driving position	min./max.	h ₁₄	mm	1258	1258	1258
	4.10	Height of wheel arms		h ₈	mm	80	80	80
	4.11	Auxiliary lift		h ₉	mm	-	762	-
	4.14	Platform height, raised		h ₁₂	mm	1195	1195	1195
	4.15	Fork height lowered		h ₁₃	mm	95	50 ¹	95
	4.19	Total length		l ₁	mm	2582	2887	2582
	4.20	Length including fork backs		l ₂	mm	1432	1687	1432
	4.21	Total width		b ₁	mm	800	800	800
	4.22	Fork dimensions		s/e/l	mm	57/186/1150	40/80/1200 ¹	57/186/1150
	4.24	Fork carriage width		b ₃	mm	-	800 ¹	-
	4.25	Overall fork width		b ₅	mm	564	205/733 ¹	564
	4.26	Width between wheel arms		b ₄	mm	-	-	253
	4.32	Ground clearance centre wheel base		m ₂	mm	30	30	30
4.34	Working aisle width with pallet 800 x 1200 lengthways		A _{st}	mm	2902	3149	2919	
4.34.1	Working aisle width with pallet 1000 x 1200 crossways		A _{st}	mm	2806	3139	-	
4.35	Turning radius		W _a	mm	1345	1569	1742	
Performance	5.1	Driving speed	laden/unladen	km/h	9/10 ²	9/10 ²	10/10 ²	
	5.1.1	Driving speed backwards	laden/unladen	km/h	8/8 ²	8/8 ²	8/8 ²	
	5.2	Lifting speed	laden/unladen	m/s	0.16/0.23	0.15/0.21 (0.15/0.22) ³	0.15/0.23	
	5.3	Lowering speed	laden/unladen	m/s	0.34/0.26	0.34/0.33 (0.30/0.13) ³	0.34/0.26	
	5.8	Max. gradeability	laden/unladen	%	5/7	7/7	8/10	
	5.9	Acceleration time	laden/unladen	s	5.7/5.2	6.2/5.6	6.2/5.4	
5.10	Service brake				Electromagnetic	Electromagnetic	Electromagnetic	
Electric engine	6.1	Drive motor, rating S2 = 60 min.		kW	2.3	2.3	2.3	
	6.2	Lift motor, rating at S3		kW	2.2/6%	2.2/6%	2.2/6%	
	6.3	Battery according to DIN 43531/35/36 A, B, C, no			No	No	No	
	6.4	Battery voltage/rated capacity K _s		V/Ah	24/345-375	24/400-500	24/345-375	
	6.5	Battery weight ±5% (depending on manufacturer)		kg	295	377	295	
	6.6	Energy consumption according to VDI cycle		kWh/h	1.1	0.99	1.61	
Misc.	8.1	Transmission control			AC control	AC control	AC control	
	10.7	Noise level (at operator's ear)		dB(A)	<70	<70	<70	

¹ Standard version with adjustable forks; for platform with fixed forks h₁₃ = 65 mm; s/e/l = 60/180/1150 mm; b₃ = 700 mm; b₅ = 560 mm

² Up to a platform height of 300 mm above the ground

³ Fork speed

OXV Vertical Order Picker
 Technical Drawings

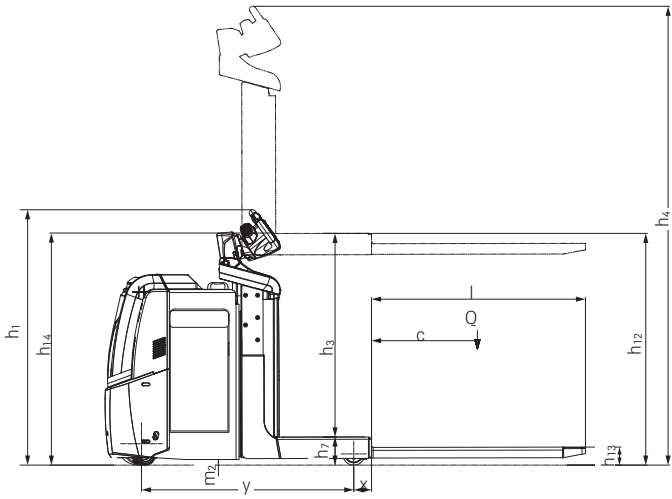

Side view OXV 07

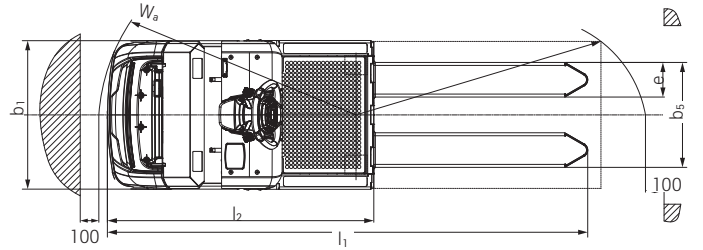

Top view OXV 07

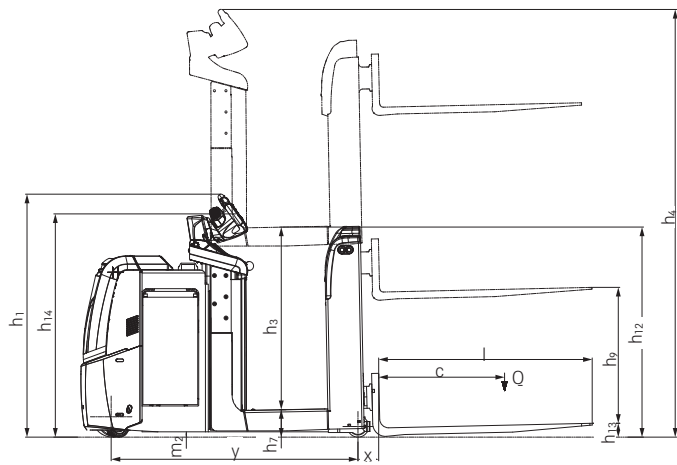

Side view OXV 08

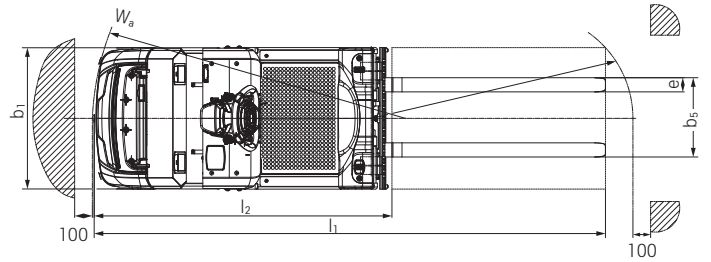

Top view OXV 08

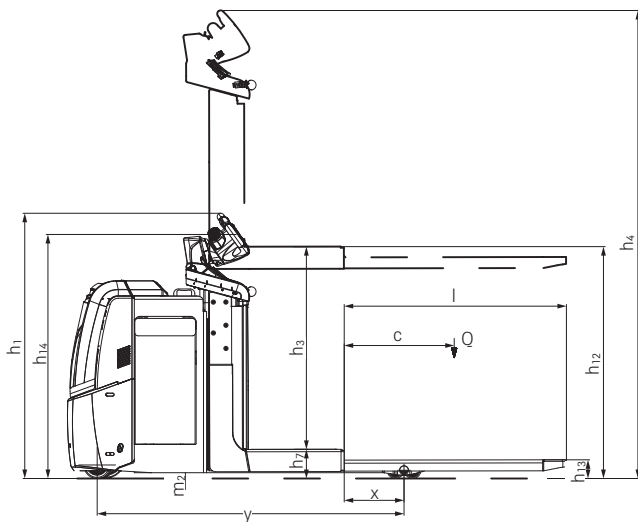

Side view OXV 10

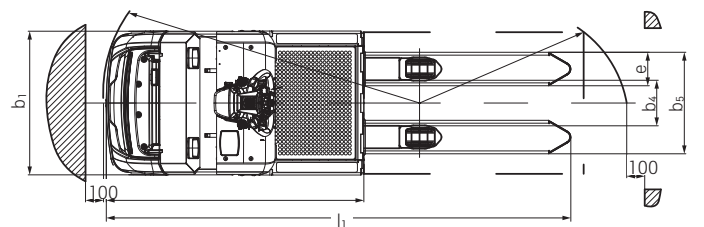

Top view OXV 10

Residual load capacity

Residual load capacity at maximum height			Load centre distance c		Upper fork edge height $h_{13} + h_3 + h_9$
			mm	mm	mm
			500	600	-
OXV 07	Q_{res}	kg	700	600	1145
OXV 08	Q_{res}	kg	800	700	1877
OXV 10	Q_{res}	kg	1000	1000	1145

OXV Vertical Order Picker Detailed Photos



Order picking without strain on the back with the OXV 08 thanks to liftable order picking lift



Optional order-picking tray for ergonomic, back-friendly work, e.g. as shown here OXV 07



Always available thanks to lateral battery change



Always available thanks to optional lithium-ion battery



Unique STILL Easy Drive steering wheel ensures optimal driving response and allows users to operate all functions without changing hands



Optional STILL Safety Light for more safety and improved visibility of the vehicle



Intelligent LED daytime driving light improves the truck's visibility and also signals low battery status



Optimal ergonomics owing to the height-adjustable steering wheel at a slight angle for individual operator preferences

OxV Vertical Order Picker
Next Level Order Picking



OXV Vertical Order Picker Next Level Order Picking

Efficient and straightforward order-picking due to low entry point of only 145 mm

Easy access to pallets due to forks welded to the truck

Order-picking even in the most confined spaces due to compact design

Intuitive working thanks to STILL Easy Drive steering wheel and optional STILL Easy Move additional lever for raising the driver platform



OXV 07 and OXV 10

Fast, efficient and safe – three words that perfectly sum up order picking with the OXV 07 and OXV 10. The vertical order pickers excel in all types of distribution centres and warehouses. Agile and compact, they smoothly move through even the narrowest warehouse aisles. They can lift up to 700 kg, respectively 1000 kg, on a pallet up to the first or second rack level. The height-adjustable driver's workspace is a real highlight, allowing you to achieve a reach height of up to 2,800 mm.

For fast order picking, the driver's platform can even be raised and lowered during travel. Features like the intuitive steering wheel and speed reduction when cornering help to ensure enjoyable, safe and convenient driving. You can also choose between a wide range of equipment options for any application – such as LED lights and various battery systems.

Back-friendly order picking due to standard auxiliary lift

Flexible transport of a wide variety of load carriers thanks to adjustable forks

Picking on the first and second rack levels up to a reach height of 2,800 mm

Maximum safety when order-picking thanks to two-handed operation of the auxiliary lift



OXV 08

The OXV 08 is every bit the equal of its sister model – it is also suitable for all industries and impresses thanks to its convenience and safety. In comparison to the OXV 07, however, this powerhouse can effortlessly lift 100 kg more, i. e. 800 kg in total. The platform lift is complemented by an auxiliary lift which enables the forks to be raised to a total height of up to 1,877 mm. The auxiliary lift can be operated with two

hands, guaranteeing safe usage in warehouse operation even during peak times. The flexibly adjustable forks allow users to pick up a wide range of load carriers and master all manner of transport tasks. In combination with the OPX horizontal order picker for work at ground level or as a partner for the EK-X vertical order picker, you will achieve unrivalled order picking performance.

OXV Vertical Order Picker

The 'Simply Efficient' factors: Performance attributes as a measure of economic efficiency



Simply easy

- STILL Easy Drive steering wheel enables intuitive operation of all functions without changing hands
- Low entry point for convenience and high order picking performance
- Responsive and safe driving behaviour: steering wheel with automatic neutral position
- Operational at all times: optional STILL lithium-ion technology for maximum availability



Simply powerful

- Picking on first and second rack level: picking heights of up to 2,800 mm
- Excellent handling capacity: the OXV 10 lifts pallets of up to 1000 kg
- Fast travel: powerful acceleration and speeds of up to 10 km/h



Simply safe

- Superb visibility: optional LED daytime driving light, Safety Light and Safety Light 4Plus
- Protection against incorrect operation: optional access control with FleetManager 4.x

- Safe cornering: Curve Speed Control depending on steering angle
- Avoid impact damage: versatile collision protection options available
- Precise handling: high-precision hydraulics and agile driving dynamics



Simply flexible

- Individual made-to-measure production: multitude of equipment options for any application
- Transport of various load carriers: adjustable forks on the OXV 08
- Suitable for any warehouse: compact dimensions and optimal manoeuvrability
- Low energy costs at the push of a button: Blue-Q efficiency mode for optimal cost-efficiency or BOOST mode for maximum order-picking performance



Simply connected

- Connects to your fleet: optional interface for integration into fleet management software such as STILL neXXt fleet
- Controlled use: optional access control protects against incorrect operation

Equipment Variants

		OXV 07	OXV 08	OXV 10
Operator's workspace	Platform lift h_{12} = 1,195 mm; total lift height of forks 1,145 mm	●	—	●
	Platform and auxiliary lift; total lift height of forks h_3 = 1,877 mm	—	●	—
	Front foil holder	○	○	○
	Low-level accessory bracket with order-picking tray	○	○	○
	Low-level accessory bracket	○	○	○
	Adjustable A4 writing pad on accessory bracket on the drive end	○	○	○
	12 V power socket	○	○	○
Steering	STILL Easy Drive operating instrument	●	●	●
	Height-adjustable STILL Easy Drive operating instrument	○	○	○
	STILL Easy Move rocker switch for even easier operation of lifting functions	○	●	○
	Pedestrian operation via butterfly switch on steering wheel and lateral push buttons	—	○	—
	Pedestrian operation via push buttons on the side of the backrest	—	○	—
Forks	Forks, not adjustable	●	○	●
	Various fork dimensions, adjustable in different dimensions	—	●	—
Battery system	Battery compartment for battery up to 375 Ah	●	—	●
	Battery compartment for battery up to 500 Ah	○	●	○
	STILL Lithium-Ion battery up to 410 Ah	○	○	○
	Cold store version for alternating applications down to -32 °C	○	○	○
Additional equipment	Lithium-ion version	○	○	○
	Provision for material flow management system	○	○	○
	Data transfer via Bluetooth	○	○	○
	Data transfer via GPRS	○	○	○
	FleetManager: access via PIN code, chip, card, customer card/chip	○	○	○
	Fork lift with lowering lock when driving	○	○	○
Safety and performance	Access authorisation (key)	●	●	●
	Access authorisation (digicode)	○	○	○
	Range of collision protection options	○	○	○
	Proportional speed reduction with load	●	●	●
	LED daytime driving light, front	○	○	○
	LED daytime driving light Plus	○	○	○
	STILL Safety Light or STILL Safety Light 4Plus	○	○	○
	Foot guard	—	○	—
	Shock detection	○	○	○
	Shock detection and activation of creep-speed mode	○	○	○

● Standard ○ Option — Not available



STILL GmbH
Berzeliusstr. 10
22113 Hamburg
Germany

Tel.: +49 40 73 39 20 00

Fax: +49 40 73 39 20 01

info@still.de

For further information please visit

www.still.eu

STILL is certified in the following areas: Quality management, occupational safety, environmental protection and energy management.



first in intralogistics