

Baoli KBD/G 25-35

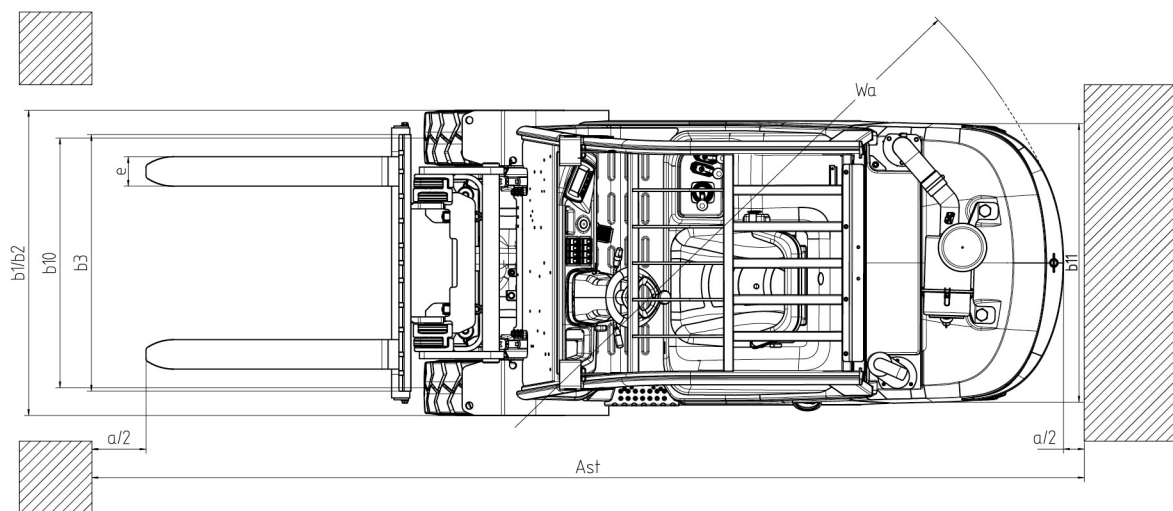

Baoli

1.1	Manufacturer		KION BAOLI
1.2	Manufacturer's type designation		KBD 35 G1 EU5
1.3	Drive: electric, diesel, petrol, fuel gas		Diesel
1.4	Operator type: hand, pedestrian, standing, seated, order-picker		Seated
1.5	Rated capacity / Rated load	Q (t)	3,5
1.6	Load centre distance	c (mm)	500
1.8	Load distance, centre of drive axle to fork	x (mm)	509
1.9	Wheelbase	y (mm)	1760
2.1	Service weight	Kg	5060
2.2	Axle loading, laden front/rear	Kg	7420/1160
2.3	Axle loading, unladen front/rear	Kg	1880/3180
3.1	Tyres: solid rubber, superelastic, pneumatic, polyurethane		SE
3.2	Tyre size, front		225/75-15
3.3	Tyre size, rear		6,50-10
3.6	Tread, front	b10 (mm)	1030
3.7	Tread, rear	b11 (mm)	953
4.1	Tilt of mast/fork carriage forward/backward	α/β (°)	6/12
4.2	Height, mast lowered	h1 (mm)	2136
4.3	Free lift	h2 (mm)	150
4.4	Lift	h3 (mm)	3000
4.5	Height, mast extended	h4 (mm)	3705
4.7	Height of overhead guard (cabin)	h6 (mm)	2221
4.8	Seat height/stand height	h7 (mm)	1223
4.12	Coupling height	h10 (mm)	432
4.19	Overall length	l1 (mm)	3780
4.20	Length to face of forks	l2 (mm)	2780
4.21	Overall width	b1/b2 (mm)	1265
4.22	Fork dimensions ISO 2331	s/e/l (mm)	50x150x1000
4.23	Fork carriage ISO 2328, class/type A, B		III A
4.24	Fork carriage width	b3 (mm)	1100
4.31	Ground clearance, laden, below mast	m1 (mm)	144
4.32	Ground clearance, centre of wheelbase	m2 (mm)	159
4.34.1	Aisle width for pallets 1000 x 1200 crossways	Ast (mm)	4220
4.34.2	Aisle width for pallets 800 x 1200 crossways	Ast (mm)	4420
4.35	Turning radius	Wa (mm)	2510
4.36	Internal turning radius	b13 (mm)	673.5
5.1	Travel speed, laden/unladen	km/h	17/17,5
5.2	Lift speed, laden/unladen	m/s	0,500/0,550
5.3	Lowering speed, laden/unladen	m/s	0,400/0,450
5.5	Drawbar pull, laden/unladen	kN	16,3/10,9
5.7	Gradeability, laden/unladen	%	20/22
5.10	Service brake		Mech/Hydr
7.1	Engine manufacturer/type		Doosan D24 EU5
7.2	Engine power according to ISO 1585	kW	45
7.3	Rated speed	min-1	2400
7.4	Number of cylinders/displacement	cm3	4/2400
7.5	Fuel consumption according to VDI cycle	l/h or kg/h	4,1 l/h
7.9	Vehicle electrical system voltage	V	12
8.1	Type of drive unit		Hydrodynamic
10.4	Fuel tank, capacity	l/kg	62.7
10.8	Towing coupling, type DIN		Pin

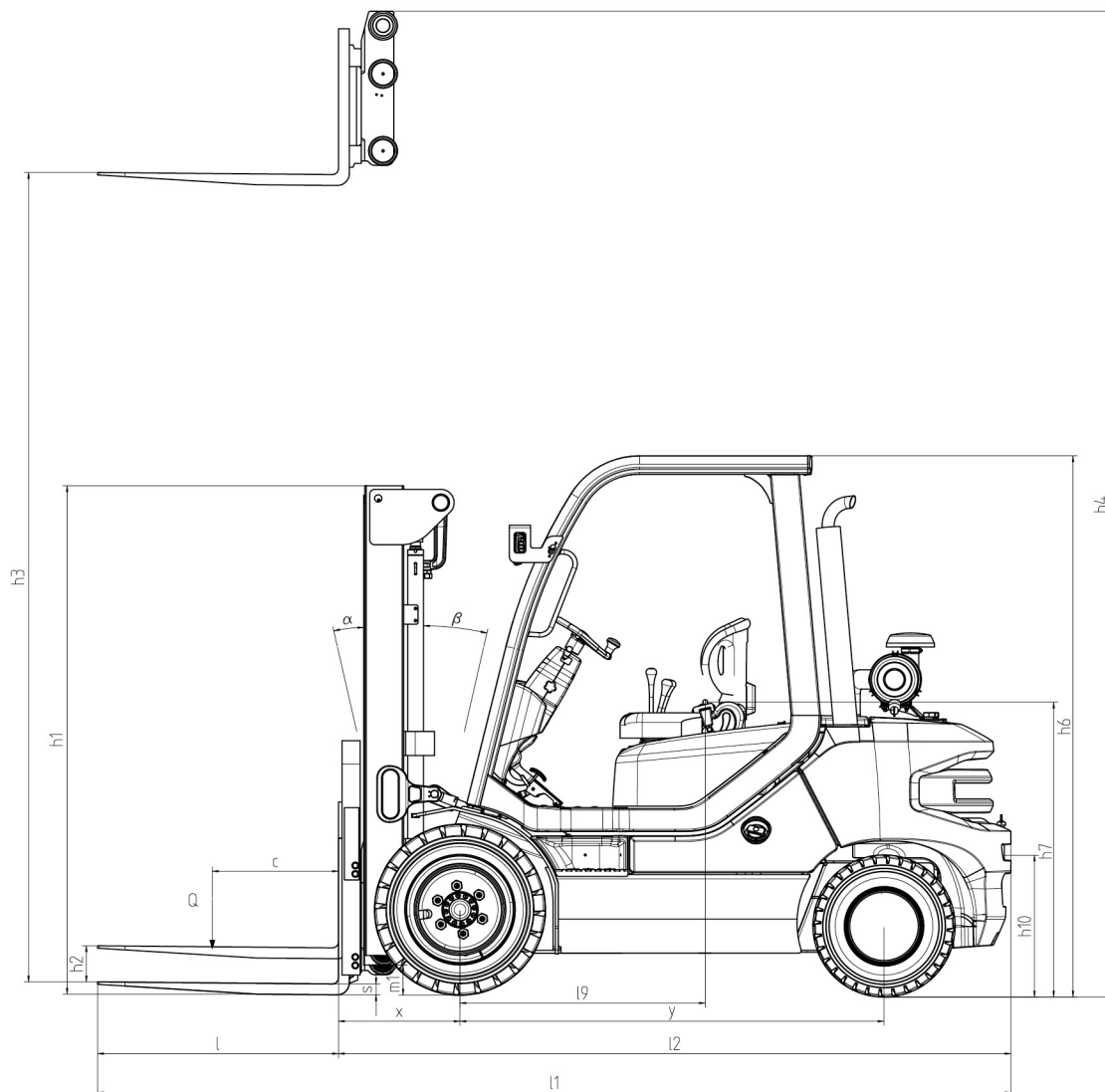

KBD 35 G1 EU5

Mast type	H3	Capacity - Load center 500 mm	Capacity - Load center 500 mm - with Sideshift	H1	H4	H2
VM Tele	3000	3500	3150	2147	3715	150
	3250	3500	3150	2247	3965	150
	3500	3500	3150	2447	4215	150
	4000	3500	2740	2747	4715	150
	4500	2970	2290	2997	5215	150
	5000	2500	1850	3247	5715	150
	5500	2020	1400	3497	6215	150
VFM 2 stage	3000	3500	3150	2112	3752	1353
	3300	3500	3150	2312	4052	1553
	3500	3500	3150	2412	4252	1653
	4000	3500	2740	2712	4752	1953
	4500	2970	2290	2962	5252	2203
VFHM triplex	4350	2970	2420	2162	5102	1403
	4500	2840	2280	2212	5252	1453
	4650	2710	2150	2212	5402	1453
	4800	2580	2030	2212	5552	1453
	5000	2400	1870	2412	5752	1653
	5500	1970	1480	2662	6252	1903
	6000	1530	1090	2912	6752	2153
	6500	1000	700	3112	7252	2353

Baoli KBD/G 25-35



The KBD/G 25-35 forklifts are designed to provide reliability, productivity and cost effectiveness. Manufactured in the new KION production plant in Jinan, the KBD/G 25-35 is the perfect choice for almost all applications. The KBD 25-35 series is available with load capacities of 2.5, 3.0 and 3.5 tonnes. Diesel trucks are equipped with a powerful Doosan engine, EU5-compliant; the Weichai engine is offered for the markets where CE conformity is not required. The KBG 25-35 series with Doosan LPG engine offers the same load capacities as the diesel models. The KBD/G 25-35 forklifts are equipped with high-quality and smooth hydrodynamic transmission. The new mast design, with lifting height up to 6.500 mm, provides wider view for operator. The mast profile and the layout of the hoses guarantee excellent view of the fork tips and the load ensuring safe and fast good handling. The fork carriage is offered with 6 rollers as a standard with option for 8 rollers; customer benefit is lower maintenance cost due to higher rollers and mast profile durability compared with 4-roller fork carriage. The options of hang-on or integrated side-shifter ensure faster loading and unloading operations. The drive compartment has been designed focusing on operator's

comfort and safety: suspended driver's cabin, comfortable seat, adjustable steering wheel, electric forward / reverse travel direction switch, foot activated parking brake, side-mounted hydraulic levers, multicolor display, storage compartments, USB chargers, rear handle with horn. The suspension system for the overhead guard absorbs vibrations caused by uneven floors. The foot activated parking brake ensures less effort to engage and disengage it compared to hand parking brake. The color screen display provides the driver with a wide range of information on truck status: hour meter, fuel level, travel speed, request of planned maintenance, alarm state. Safety and visibility are further enhanced by a comprehensive range of available lights: front/rear lights, front/rear working spotlights, front/rear blue spot and flashing beacon. The lights are with LED technology for lower energy consumption and are protected by metal covers for higher durability. The overhead guard is offered with retrofittable half / full cabin option; customer has the flexibility to upgrade the truck to half or full cabin version. The quality of the components and the accessibility for maintenance operations ensure outstanding reliability.

Technology

- ✓ Powerful Doosan and Weichai engines suitable for all EMEA markets
- ✓ High-quality and smooth hydrodynamic transmission
- ✓ Lower maintenance cost with 6 / 8-roller fork carriage
- ✓ Many options for safety lights: front/rear lights, front/rear working spotlights, front/rear blue spot and flashing beacon
- ✓ Lights with LED technology for lower energy consumption
- ✓ Easy access to all main components for maintenance operations
- ✓ Metal engine compartment bonnet for maximum resistance and functionality
- ✓ Inching pedal for high precision handlings
- ✓ Color screen display with wide range of information for the driver
- ✓ Electric forward / reverse travel direction switch
- ✓ Adjustable seat and steering column
- ✓ Rear handle with horn
- ✓ Very large and comfortable operator footboard
- ✓ Overhead guard offered with retrofittable half / full cabin option

Ergonomics and workplace

- ✓ New mast design: wider view for operator
- ✓ Drive compartment designed focusing on operator's comfort and safety
- ✓ Overhead guard suspended to absorbs vibrations
- ✓ Foot activated parking brake: less effort for engaging / disengaging

